

**ENGINE MODEL L 1306 C2****TECHNICAL DATA**

No. Cylinder & Arrangement	6 in line
Bore	130 mm
Stroke	142 mm
Total Displacement	11,31 l
Compression ratio	15,4
Valves per cylinder	2 intake
	2 exhaust

**PERFORMANCES****L 1306 C2 MLL****Rated Power ICFN 440 kW**

Speed	2400 rpm
B.M.E.P.	19,45 bar
Emissions compliance	IMO MARPOL Tier II / EPA Tier II Without After Treatment System
Mean piston speed	11,4 m/s
Idle speed	700 rpm

**L 1306 C2 MSD****Rated Power ICFN 590 kW**

Speed	2600 rpm
B.M.E.P.	24,1 bar
Emissions compliance	IMO MARPOL Tier II / EPA Tier II Without After Treatment System
Mean piston speed	12,3 m/s
Idle speed	700 rpm

**AMBIENT REFERENCE CONDITIONS**

According to Marine Classification Societies requirements  
(ISO 3046/1 for unrestricted navigation)

Ambient temperature	45° C
Sea water temperature	32° C
Barometric pressure	1000 mbar
Relative humidity	60%

**Rated power available without any derating up to:**

Ambient temperature	55° C
Sea water temperature	36° C
Relative humidity	100%



*Isotta Fraschini Motori*  
a **FINCANTIERI** company

the added value to your project

## L 1306 C2

### MARINE DIESEL ENGINE

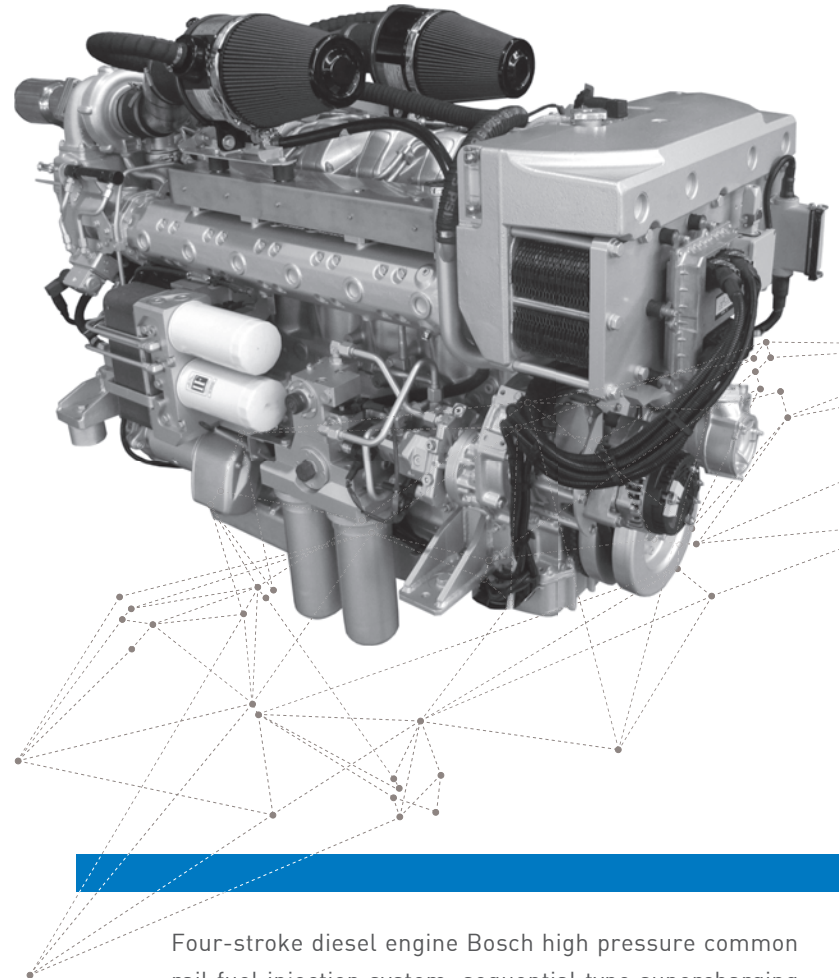

Four-stroke diesel engine Bosch high pressure common rail fuel injection system, sequential type supercharging system with exhaust gas operated turbochargers and tube-type sea water/charge air intercoolers, engine cooling system with fresh water/sea water plate type heat exchanger with integrated header tank and thermostatic control, thermal insulated exhaust gas manifolds.

Single cylinder heads with 4 valve technology; efficient combustion with low fuel consumption; outstanding low end torque for excellent acceleration and reliable high output power, in all operating conditions.

Engine with exclusive power to weight ratio.

## PERFORMANCE DIAGRAM

### L 1306 C2 ENGINE

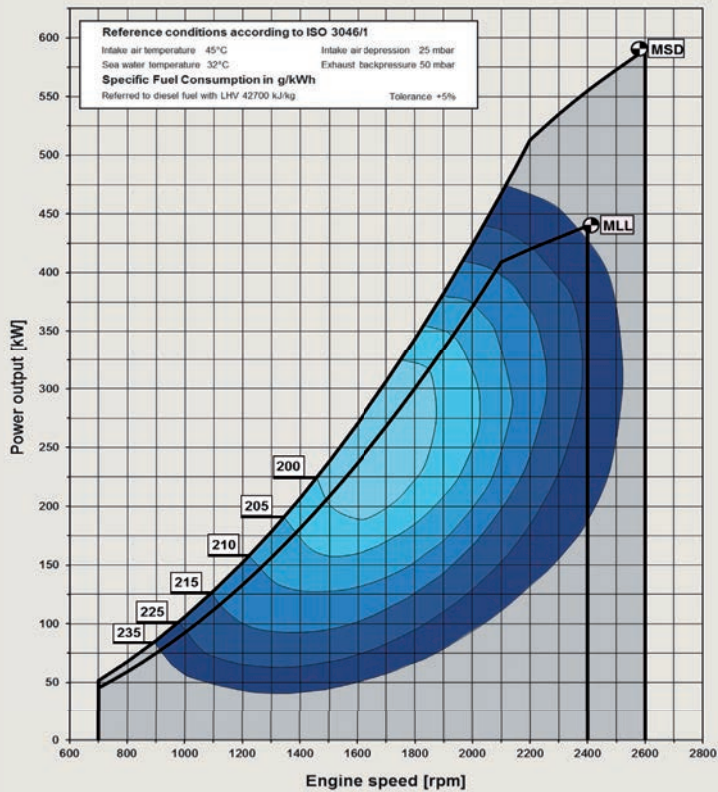

NOTE: Engines Power in reference to ISO 3046 -1

#### BASIC ENGINE BUILD STANDARD

- Engine cooling circuits with engine-driven centrifugal pumps (sea water pump of self-priming type)
- Forced engine lubrication by engine-driven gear type pump, plate-type oil/ fresh water cooler unit, cartridge type oil filter unit
- Fuel system complete with BOSCH High Pressure pump with feeding pump
- Duplex fuel filter, cartridge replaceable whilst running
- Electric system provided with terminal box
- Electric starting motor (24V x 6,6kW)
- Alternator for battery charging (28V, 100A)
- Exhaust gas bellows
- Intake air bellows
- Flexible mountings
- Electric pre-lubrication pump
- Shielded High Pressure Injection pipes
- Torsional vibration damper
- Local Control Panel (LCP)
- Standard tools
- Operating and maintenance manual (commercial type)
- Illustrated spare parts catalogue (commercial type)

#### PRESSURE SENSORS:

- Charge air pressure
- Lube oil pressure
- Fresh waterpressure
- Sea water pressure
- Fuel oil pressure

#### TEMPERATURE SENSORS:

- Charge air temperature
- Fresh water temperature
- Lube oil temperature
- Fuel oil temperature
- Exhaust gas temperature

#### NOTE

All technical data are subject to variation without notice.  
 To be used only as indicative.  
 To be confirmed with a purchase order.

## L 1306 C2 MARINE DIESEL ENGINE

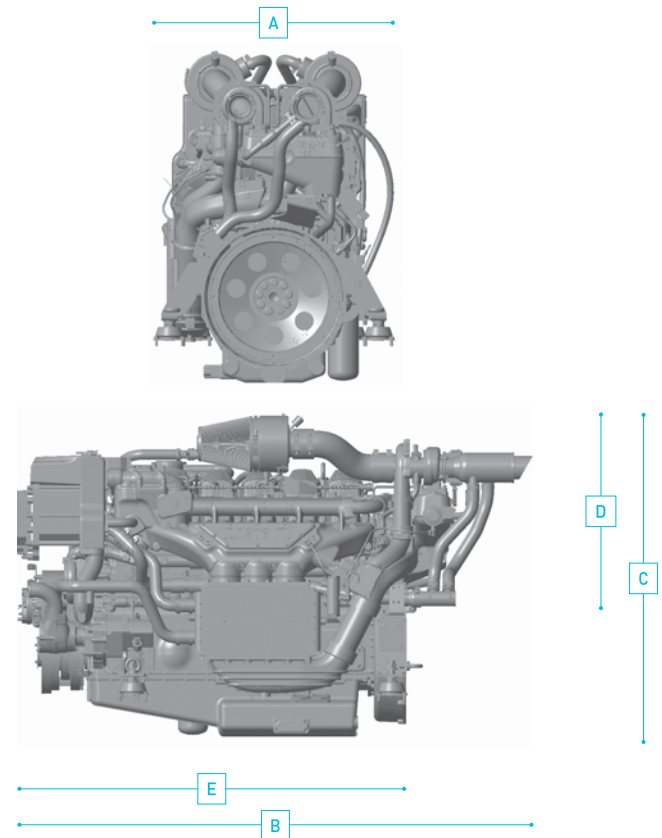

#### DIMENSIONS & WEIGHTS

A	Engine Width	804 mm	E	Length at Flywheel	1448 mm
B	Engine Length	1631 mm	F	Engine Dry mass	980 Kg
C	Engine Height	1250 mm	I	Flywheel and Housing size	SAE 14 SAE 1
D	Height at Engine shaft	935 mm			

#### OPTIONAL ITEMS

- Overspeed engine stopping device
- Marine painting
- Fresh water pre-heating system with thermostat system
- Lube oil pre-heating system with thermostat system
- Remote Control Panel-Dashboard
- Throttles kit
- Reverse & reduction gear box (torsional coupling included)
- Cardan shaft
- Classification society test certificate
- Torsional vibration analysis calculation (TVC)
- Long storage preservation treatment
- Pneumatic starting system
- Intake air dry type filters
- Bilge Pump
- Turning gear



*Isotta Fraschini Motori*  
a FINCANTIERI company

isottafaschini@isottafaschini.it - www.isottafaschini.it

